



Bodyguard™

User Guide



Britax



Safety Information 2-5

Vehicle Safety Belts 6

Vehicle Seating Positions 7

Features 8-9

Adjustments 10-11

Securing the Child 12-13

Care and Maintenance 14-15

Warranty 16



WARNING

DEATH or SERIOUS INJURY can occur:

- Use only with children whose height is between 43 and 60 inches (109 and 152 cm).
- Use only the vehicle's lap and shoulder belt system when restraining the child in this seat.
- Secure this child restraint with a vehicle belt.
- Follow all instructions on this child restraint and in the written instructions.
- Register your child restraint with the manufacturer.
- Use restraint forward facing only!
- This child restraint must not be used in the home, in boats, or other non-certified applications.
- Secure this child restraint even when it is not occupied. In a crash, an unsecured child restraint may injure vehicle occupants.
- This booster seat is **not** compatible with vehicle child restraint anchorage systems (LATCH).
- Do not use this booster with two-point vehicle belts (lap belt only or shoulder belt only). Your child would be seriously injured in the event of a crash.
- Do not disconnect the base and backrest. The base and backrest must always be used together.
- Based on crash statistics, the National Highway Traffic Safety Administration recommends that parents select the rear seat as the safest location for a properly installed child restraint. Please study the section on *Vehicle Safety Belts* in this booklet to ensure the child's safety. If in doubt about installing the child restraint, consult the vehicle owner's manual.

- The primary protection for occupants of a vehicle in a collision is the body of the vehicle itself; a child restraint will not protect a child when the vehicle is seriously impacted. However, correctly installed, a child restraint will substantially improve the chances for survival in most crashes. Make sure that all users fully understand the correct ways to use this child restraint in a vehicle.
- Do not, except as described in this book, attempt to disassemble or modify any part of the booster seat or vehicle belts.
- Do not leave loose objects, e.g. books, bags, etc., in the back of a vehicle. In the event of a sudden stop, loose objects will keep moving, potentially causing serious injuries.
- Do not leave folding vehicle seats unlatched. In the event of a sudden stop, a loose seat back could prevent the restraint from protecting the child as well as it should.
- Do not use anything to raise the booster seat off the vehicle seat.
- Do not allow children to play with this booster seat.
- Do not leave children alone in a vehicle, even for a short time.



DO NOT place a child restraint in the front seat of a vehicle with a passenger air bag unless the air bag is turned off. **DEATH or SERIOUS INJURY** can occur. The back seat is the safest place for children under 12.

Maximum Height

Child is too tall when top of ears are above the top of a fully raised headrest.

**Certification**

This child restraint system conforms to all applicable Federal motor vehicle safety standards. **This restraint is not certified for use in aircraft.** Lap belts provided in aircraft cannot be used safely with this product.

Registration

Fill out the registration card and mail it in today!

Child restraints could be recalled for safety reasons. You must register this restraint to be reached in a recall. Send your name, address, and the restraint's model number and manufacturing date to the manufacturer, Britax Child Safety, Inc. 13501 South Ridge Drive Charlotte, NC 28273 or call 1-888-4BRITAX. For recall information, call the U.S. Government's Auto Safety Hotline at 1-800-424-9393 (202-366-0123 in DC area).

You may also register by visiting BritaxUSA.com.

Important Notes

- Set a good example by always wearing your seat belt. Make it a firm rule that the vehicle does not move until everyone is buckled up. Make no exceptions for adults or children.
- Cover the booster with a towel or blanket when the vehicle is parked in direct sunlight. Parts of the booster seat could become hot enough to burn the child.
- Store the booster seat in a safe place when not in use. Do not place heavy objects on top of the booster while in storage.
- To prevent injury due to deterioration, hidden damage, lost instructions, outdated technology, etc., discontinue use of a booster seat that is older than six years or has been in a severe crash.

Vehicle Safety Belts

IMPORTANT: Some vehicles have no seating positions that are compatible with this booster seat, or any other booster seat. If in doubt, contact the vehicle manufacturer for assistance.

To protect your child in a crash, you must use this booster seat with vehicle safety belts that are compatible. This booster can only be used with three-point (shoulder and lap) safety belts that are not motorized or anchored on the vehicle door.

The following types of vehicle belts are **not** compatible with this booster seat:

- ✗ Two-point belts of any kind.
- ✗ Front vehicle belts with top or bottom anchorage points in the door.
- ✗ Motor driven automatic vehicle belts.
- ✗ Three-point belts that have separate retractors for the shoulder section and the lap section.

The vehicle owner's manual will have information on the types of seat belts in the vehicle. If the belt type is listed above, select another seating position.

This booster seat can fit securely in most vehicles using the existing vehicle belts. However, some types of vehicle designs prevent a secure fit, due to the position of the vehicle belt lower anchorage points.

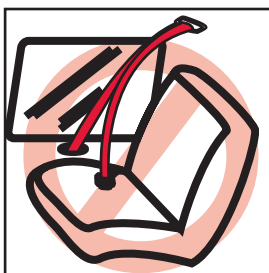
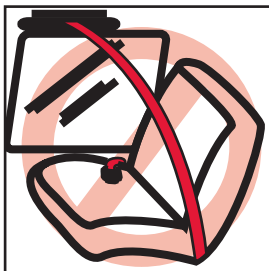

Vehicle Seating Positions

WARNING!

- Britax and the U.S. Department of Transportation warn that children 12 and under must ride in the rear seats, away from front air bags. The only exception is if the air bag is turned off. When using in vehicle with air bags, refer to the vehicle owner's manual for additional child restraint installation instructions and precautions.
- Forward facing vehicle seats **MUST** be used with this booster seat. Side facing or rear facing seats in vans, station wagons or trucks **CANNOT** be used.

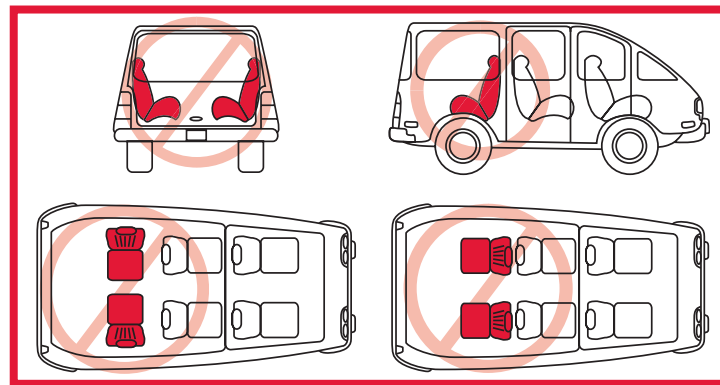

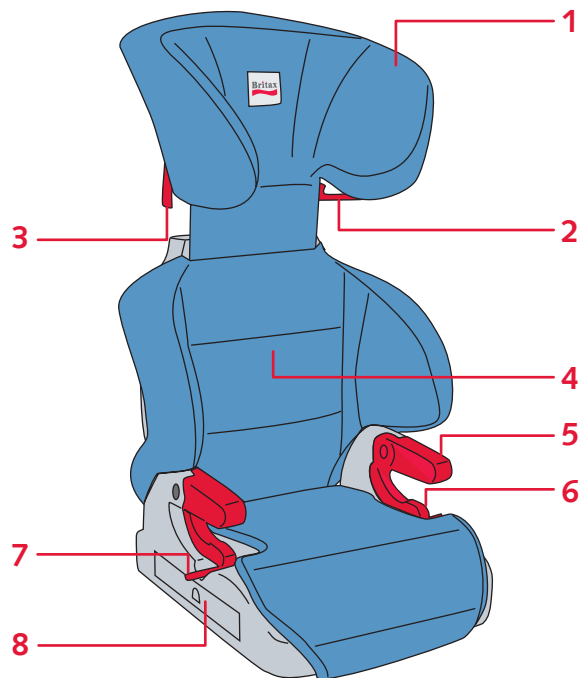

- 1 Headrest
- 2 Left Side Beltguide
- 3 Right Side Beltguide
- 4 Backrest
- 5 Armrest
- 6 Lock-off

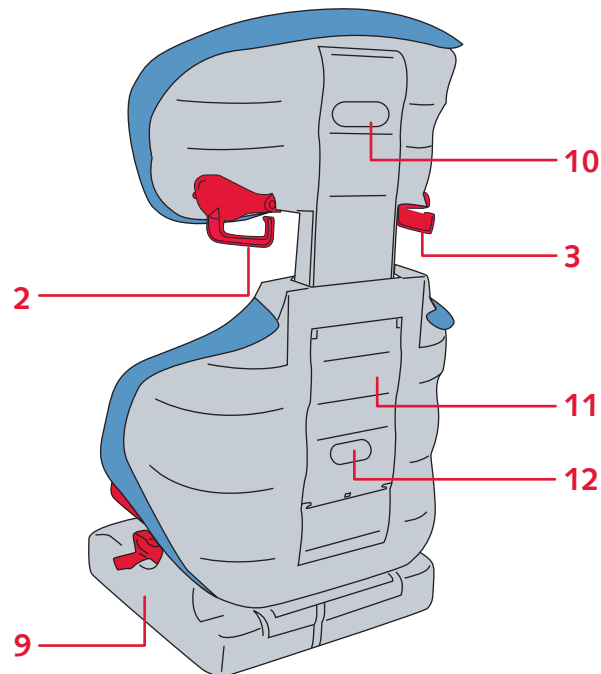

- 7 Lock-off Release
- 8 Seat Compartment
- 9 Base
- 10 Headrest Adjust Handle
- 11 Recline Flap
- 12 Recline Handle

Adjusting the Base

Adjust the base width to provide the best fit for your child. The armrests of the booster should be snug against the hips of the child to properly align the lap belt across the hips.

1 Check the current fit with the child seated in the booster seat.

- *Make note of the approximate adjustment required to achieve a fit that is snug against the child's hips.*

2 Turn the empty booster seat over to access width adjustment knob on the bottom of the base.

3 Turn adjustment knob counter-clockwise to loosen (Fig. A).

4 Slide base to adjust width for a fit that is snug against the child's hips (Fig. B).

5 Turn adjustment knob clockwise until completely tight (Fig. C).

NOTE: As your child grows, further width adjustments will be necessary.

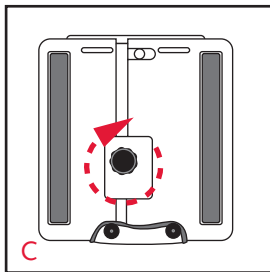
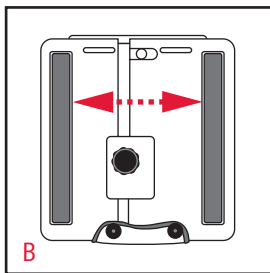
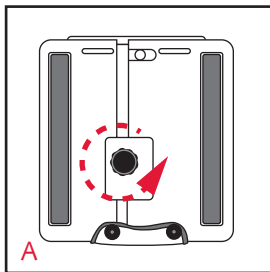

Adjusting Headrest Height

Use the eleven-position headrest to adjust the height of the booster seat.

1 Check the current fit with the child seated in the booster seat.

- *Make note of the approximate adjustment required to achieve a fit that brings the beltguides even with the child's shoulders.*

2 Squeeze the handle to release headrest lock (Fig. D).

3 Slide headrest up or down so the beltguides are even with, or just above, the child's shoulders (Fig. D).

4 Release handle to lock position of headrest.

Adjusting Backrest Angle

Use the two-position recline flap to adjust the back angle of the booster seat.

- **Reclined Backrest Position:** Pull flap out, then slide down until in reclined position (Fig. E).
- **Upright Backrest Position:** Pull flap out, then slide up until in upright position, flush with backrest (Fig. F).

IMPORTANT: Whether in reclined or upright position, recline flap should always be in full contact with vehicle seat when booster is installed.

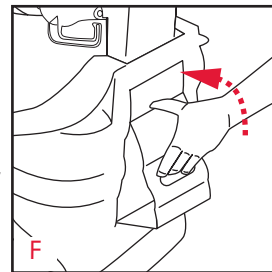
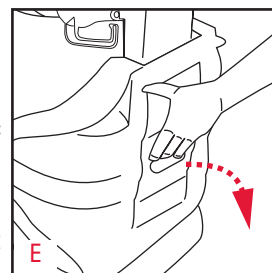
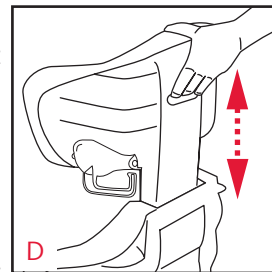

Securing the Child

1 Place the booster seat in a vehicle seating position equipped with a lap-shoulder belt (Fig. A).

- Refer to pages 6–7 to determine the best seating position for the child.

2 Position the booster seat so that the backrest is flat against the vehicle seat.

- To adjust backrest angle, refer to page 11.

3 With child properly seated in booster seat, open both lock-offs by lifting up on each lock-off release tab (Fig. B).

4 Position lap portion of the vehicle belt under each lock-off, verify that vehicle belt is not twisted, then buckle.

5 Position the shoulder portion of the vehicle belt over the armrest closest to the buckle, then through the appropriate beltguide on the headrest. (Fig. C).

- If necessary, make adjustments to the height of the headrest so the shoulder belt rests on the child's shoulder. To adjust headrest, refer to page 11.

6 Remove slack from lap, then shoulder portions of the vehicle belt to provide a comfortable but snug fit for the child.

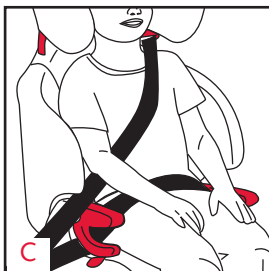
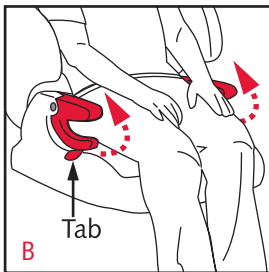
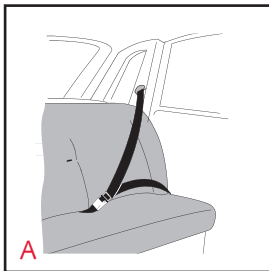

Securing the Child

7 Push down on each armrest to close the lock-offs and lock the vehicle belt in position (Fig. D).

- Verify that only the lap portion is routed through the lock-offs prior to closing. Route shoulder portion over the armrest closest to the buckle.
- A positive click indicates that the lock-off is fully locked.

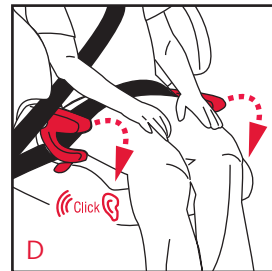

8 Verify that installation is correct (Fig. E).

TIP: After initial setup, it is only necessary to release the lock-off closest to the buckle and unbuckle the vehicle belt to allow the child to exit the restraint. To secure child using this method, buckle vehicle belt, remove slack, then secure lock-off over lap portion of belt.

IMPORTANT: This restraint is certified to FMVSS 213 with both lock-offs used. The lock-offs link the booster to the vehicle so the seat belt carries the inertia load of the booster in a crash.

Removal

- 1 Open both lock-offs by lifting up on the lock-off release.
- 2 Unbuckle vehicle belt.
- 3 Remove vehicle belt from lock-offs.

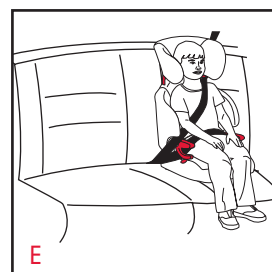

Cover Removal

TIP: Use a blunt wooden rod (pencil, chopstick, etc.) to assist with untucking the cover from the hooks on the shell.

- To remove base cover:
 - Unfasten buttons (2x) on bottom front edge of base (Fig. A-7).
 - Unfasten hook and loop strap from rear of base (Fig. A-2).
- To remove backrest cover:
 - Unhook elastic loops (2x) from attachment points on upper rear of backrest (Fig. A-3).
 - Unhook elastic loops (2x) from attachment points on lower rear of backrest (Fig. A-4).
 - Untuck cover from hooks (4x) on sides of backrest (Fig. A-5).
- To remove headrest cover:
 - Unhook elastic loops (2x) from attachment points on beltguides (Fig. A-6).
 - Unhook elastic loops (2x) from attachment points on lower rear of backrest (Fig. A-4).
 - Untuck cover from hooks (2x) at top of headrest (Fig. A-7).

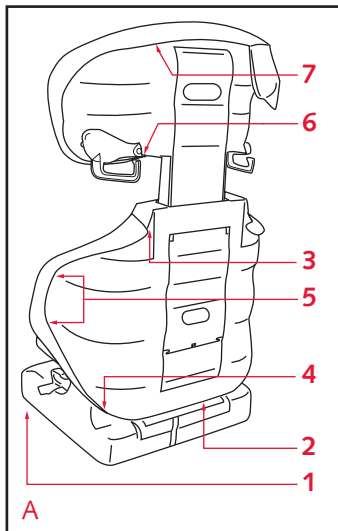

Refitting the Cover

TIP: Use a blunt wooden rod (pencil, chopstick, etc.) to assist with tucking the cover under the hooks on the shell.

- To refit headrest cover, place cover over headrest, then:
 - Hook elastic loops (2x) to attachment point on beltguides (Fig. A-6).
 - Hook elastic loops (2x) to attachment points on lower rear of backrest (Fig. A-4).
 - Tuck cover under hooks (2x) at top of headrest (Fig. A-7).
- To refit backrest cover, place cover over backrest, then:
 - Hook elastic loops (2x) to attachment points on upper rear of backrest (Fig. A-3).
 - Hook elastic loops (2x) to attachment points on lower rear of backrest (Fig. A-4).
 - Tuck cover under hooks (4x) on sides of backrest (Fig. A-5).
- To refit base cover, place cover over base, then:
 - Fasten buttons (2x) on bottom front edge of base (Fig. A-7).
 - Fasten hook and loop strap around lower backrest (Fig. A-2).

Cleaning the Cover

HAND WASH, using cold water and mild soap.

LINE DRY, to prevent cover from shrinking.

DO NOT: Bleach, machine wash, or machine dry.

Cleaning the Shell

SPONGE CLEAN, using warm water and mild soap.

TOWEL DRY

DO NOT: Use solvents, abrasive cleaners, or disassemble booster in any way, except as instructed.

Warranty

This booster seat was manufactured by Britax. Britax Child Safety, Inc. ("Britax") warrants this product to the original retail purchaser as follows:

LIMITED WARRANTY

This booster seat is warranted against defective materials or workmanship for one year from the date of original purchase. Proof of purchase is required. The exclusive remedy for this warranty is that Britax will, at its option, provide repair or replacement components for this product or refund the original purchase price of the product. Britax reserves the right to discontinue or change fabrics, parts, models or products, or to make substitutions.

To make a claim under this warranty, contact Britax Consumer Services at 1-888-427-4829 or write to us using the address on the back cover of this booklet. Proof of purchase is required.

PLEASE COMPLETE AND MAIL THE OWNER REGISTRATION CARD WITHIN (30) DAYS OF PURCHASE.

WARRANTY LIMITATIONS

This warranty does not include damages that arise from negligence, misuse or use not in accordance with the product instruction.

The use of non-Britax Child Safety, Inc. covers, inserts, toys, accessories, or tightening devices is not approved by Britax. Their use could cause this restraint to fail Federal safety standards or perform worse in a crash. Their use voids the Britax warranty.

LIMITATION OF DAMAGES

The warranty and remedies as set forth above are exclusive and in lieu of all others, oral or written, express or implied. In no event will Britax, or the retailer selling this product, be liable for any damages, including incidental or consequential damages, or loss of use arising out of the use or inability to use this product.

LIMITATIONS OF WARRANTIES AND OTHER WARRANTY TERMS AND STATE LAWS

Any implied warranties, including implied warranties of merchantability and fitness for a particular purpose, shall be limited to the duration and terms of the express written warranty. Some states do not allow limitations on how long an implied warranty lasts or the exclusion or limitation of incidental or consequential damages, so the above limitations may not apply. This warranty gives you specific legal rights, and you may have other rights, which vary from state to state. Neither Britax, nor the retailer selling this product, authorizes any person to create for it any other warranty, obligation, or liability in connection with this product.

Britax
Childcare



First class travel for children

Britax Child Safety, Inc.
13501 South Ridge Drive
Charlotte, NC 28273
USA

A **Britax Childcare** company

Tel: 704-409-1700

BritaxUSA.com